

# Breezax Axial Impellers

Aerofoil axial impellers with adjustable blade angle for the efficient movement of air in ducted or enclosed radiator applications



## SIZE RANGE

190mm to 2000mm diameter. Blades can be machined to any specified size between these limits.

## MATERIAL

Glass Reinforced Polypropylene (GRP)  
Glass Reinforced Nylon (GRN)  
Anti Static Nylon (ASTAT)  
Aluminium (AL)

## OPERATING TEMPERATURES

GRP -40°C to +70°C  
GRN -40°C to +150°C  
ASTAT -30°C to +110°C  
AL -40°C to +200°C  
(Aluminium blades have been supplied for operation at -130°C). Please consult our Sales Team for applications beyond these temperatures.

## PERFORMANCE

Quick selection of the optimum impeller for your application is available on our fan selection software.

## BLADE TYPES

A versatile range of blades, all having aerofoil designs that suit a range of installations. Refer to individual reference sheets or our selection software for more specific information.

## WORLDWIDE AVAILABILITY

Breezax Impellers are manufactured and exported on a worldwide basis to ensure prompt availability and competitive prices.

## ASSEMBLY OPTIONS

Impellers can be supplied as an assembled item or in component form for self assembly.

## HIGH EFFICIENCY

Remarkably high efficiencies are the direct result of rigorous development of our aerodynamic profiles and advanced manufacturing techniques.

## MOUNTING

Hubs can be supplied to match standard metric, or imperial (NEMA) motor shaft sizes. Taper locking hubs can be supplied if required. For engine fans, our 'ED' hub can be machined to match the pulley or flange.

## HAZARDOUS AREA

For hazardous areas we can offer our anti-static blades. Aluminium blades can also be used with an anti spark track or non-sparking cowl.

## APPLICATIONS

- Electric Fan
- Diesel Engine / Radiator
- Heat Exchangers
- Air Compressors
- Moving Plant
- Hazardous Area
- Cryogenic
- Hydraulic Drive





# THE LONDON FAN COMPANY

## SAFETY

Impellers fitted to electric motors or engines fall within the scope of the Machinery Directive (89/392/EEC and amendments) and compliance with it is mandatory. It is essential that impellers are guarded and should only be operated within the specified speed and temperature limitations. Queries regarding the safe fitting and operating of impellers should be referred to The London Fan Company Ltd.

## Note

General bore tolerance to BS1916. H8 and keyways to BS4235. This information should only be used as a guide. Certified dimensions can be supplied on request.

\* K MAX and L MAX are for blade set at 40° pitch  
For maximum overall width of impeller add K & J (plan A) or L & J (plan B)

\*\* Special designed adaptor can be made to suit shafts upto Ø65mm, please refer to The London Fan Company.

Diameter Range A	Blade Profile	** Size of Bores D	Dimensions*								
			B	E	F	G	H	I	J	K MAX	L MAX
250-590	s	9.5-16	110	24	32	22	52	6	29	16	26
		19-20		30	42	27			39		
315-640	s	12-16	160	30	32	27	96	6.5	28	16	26
		19-20		34	32	31			28		
		19-20		34	42	31			38		
		22-24		42	52	38			48		
		28		45	62	41			58		
400-710	s	19-20	230	34	42	31	120	7	39	16	26
		24		42	52	38			49		
		28		45	62	41			59		
		38		62	82	58			79		
250-590	B	9.5-16	110	24	32	22	52	6	29	21	34
		19-20		30	42	27			39		
315-640	B	12-16	160	30	32	27	96	6.5	28	21	34
		19-20		34	32	31			28		
		19-20		34	42	31			38		
		22-24		42	52	38			48		
		28		45	62	41			58		
400-710	B	19-20	230	34	42	31	120	7	39	21	34
		24		42	52	38			49		
		28		45	62	41			59		
		38		62	82	58			79		
315-830	A	12-16	160	30	32	27	96	6.5	28	27	41
		19-20		34	32	31			28		
		19-20		34	42	31			38		
		22-24		42	52	38			48		
		28		45	62	41			58		
400-900	A	19-20	230	34	42	31	120	7	39	27	41
		24		42	52	38			49		
		28		45	62	41			59		
		38		62	82	58			79		

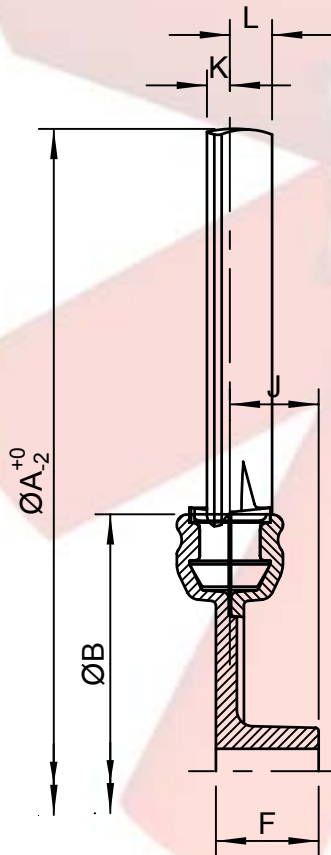

BOSS ARRANGEMENT (drawn as plan B)

Hub Size	No. Blades
110	5
	10
230	3
	6
	12

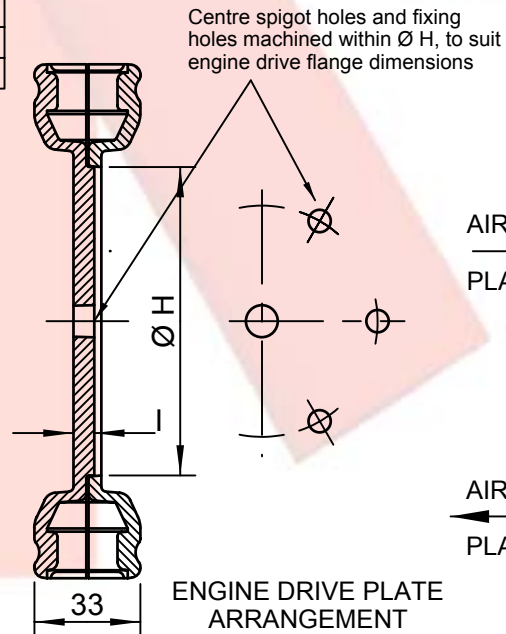
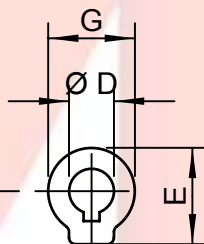

ENGINE DRIVE PLATE ARRANGEMENT



# THE LONDON FAN COMPANY

## SAFETY

Impellers fitted to electric motors or engines fall within the scope of the Machinery Directive (89/392/EEC and amendments) and compliance with it is mandatory. It is essential that impellers are guarded and should only be operated within the specified speed and temperature limitations. Queries regarding the safe fitting and operating of impellers should be referred to The London Fan Company Ltd.

## Note

General bore tolerance to BS1916. H8 and keyways to BS4235. This information should only be used as a guide. Certified dimensions can be supplied on request.

Diameter Range A	Blade Profile	** Size of Bores D	Dimensions*								K MAX	L MAX
			B	E	F	G	H	I	J			
630-1170	A	24	250	42	52	38	120	7	49	27	41	
		28		49	62	48			59			
		38		62	82	58			79			
		28-48		---	32	---			24			
		38-60		---	44	---			36			
710-1244	TX	24	250	42	52	38	120	7	49	46	65	
		28		49	62	48			59			
		38		62	82	58			79			
		28-48		---	32	---			24			
		38-60		---	44	---			36			
800-1250	A	28	330	49	62	48	220	7	59	27	41	
		38		62	82	58			79			
		28-48		---	32	---			24			
		38-60		---	44	---			36			
800-1324	TX	28	330	49	62	48	220	7	59	46	65	
		38		62	82	58			79			
		28-48		---	32	---			24			
		38-60		---	44	---			36			

\* K MAX and L MAX are for blade set at max pitch  
For maximum overall width of impeller add K & J (plan A) or L & J (plan B)

\*\* For bore sizes over 38mm Taper lock hubs are used as standard

Hub Size	No. Blades
250	3
	6
	12
330	4
	8
	12
	16

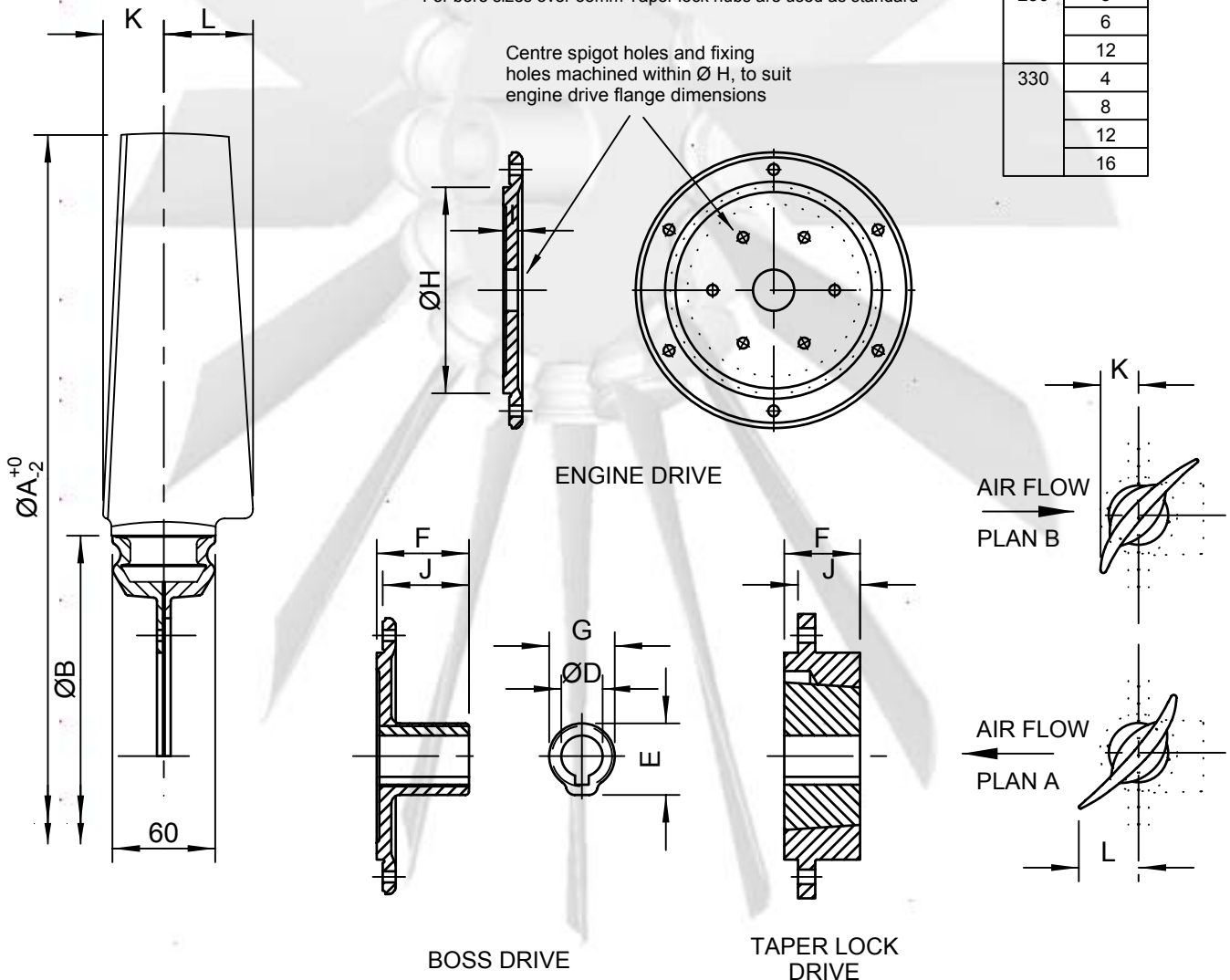



# THE LONDON FAN

## COMPANY

### 'C' TYPE IMPELLER DATA SHEET

Diameter Range A	Blade Profile	Size of Bores D	Dimensions								Hub Size	No. Blades
			B	F	G	H	J	K MAX	L MAX			
800-1324	C	42-48	400	30	120	330	0	63	88	400	4	
		55-60		60	120		30				8	
		70-85		80	160		45				12	16

#### SAFETY

Impellers fitted to electric motors or engines fall within the scope of the Machinery Directive (89/392/EEC and amendments) and compliance with it is mandatory. It is essential that impellers are guarded and should only be operated within the specified speed and temperature limitations. Queries regarding the safe fitting and operating of impellers should be referred to The London Fan Company Ltd.

#### Note

General bore tolerance to BS1916. H8 and keyways to BS4235. This information should only be used as a guide. Certified dimensions can be supplied on request.

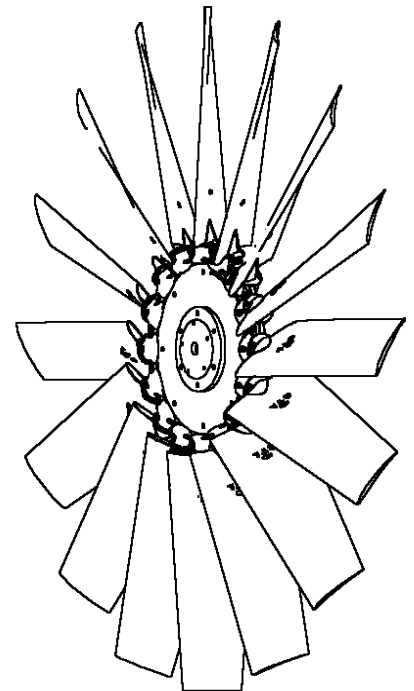

Centre spigot holes and fixing holes machined within  $\varnothing H$ , to suit engine drive flange dimensions

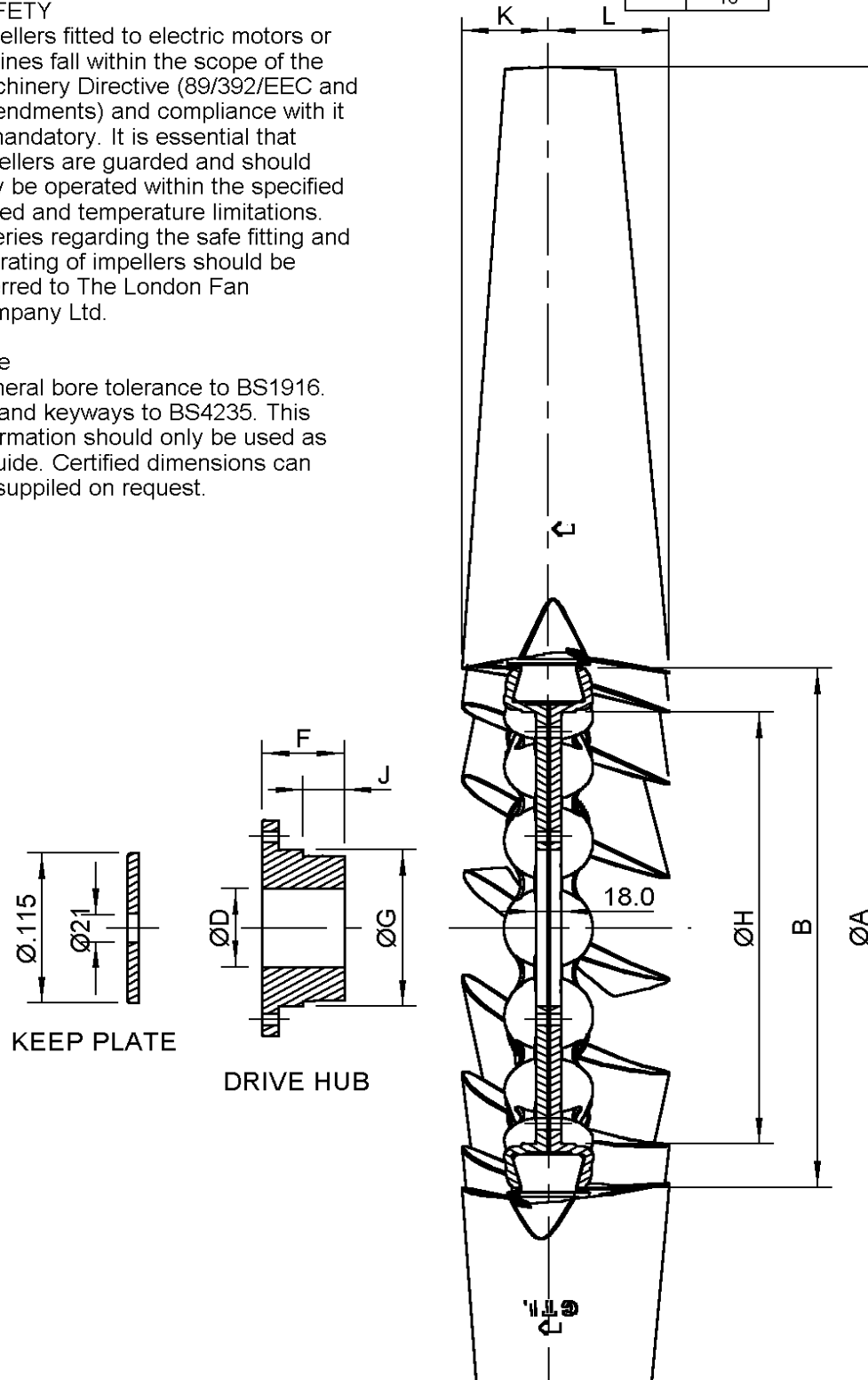

KEEP PLATE

DRIVE HUB

ENGINE DRIVE VERSION